



VIRKAR

DYNAMIC D Series

DYNAMIC D Series - Technical Specifications

Wheel with flotation tyre	550 / 45 22,5
Hopper capacity	5.300 liters ¹
Machine weight	5.000 kg ¹
Seed distribution	Pneumatic seeding system
Seed rate	From 2 to 380 kg/hectare ²
Distance between seed units	19cm / 25cm
Transport folding	Automatic lock
Dosage	Electrical (ISOBUS)
Opener and depth control	TotalContour system with quick height adjustment
Useful work height range	35 cm
Hydraulic equipment requirements	4 distributors + 1 free return
Minimum tractor power required	130 hp
Standard accessories	LED working lights
	Toolbox
	Electronic steering axle
	Machine lifting system
	Tramline
Additional features	2 Products (1.850 / 3.440 liters)
	3 Products (1.850 / 3.000 / 350 liters)
	Hopper extension (1.500 liters)
	Folder conveyor-positionable
	Hydraulic autonomous system (cardan)

Measures

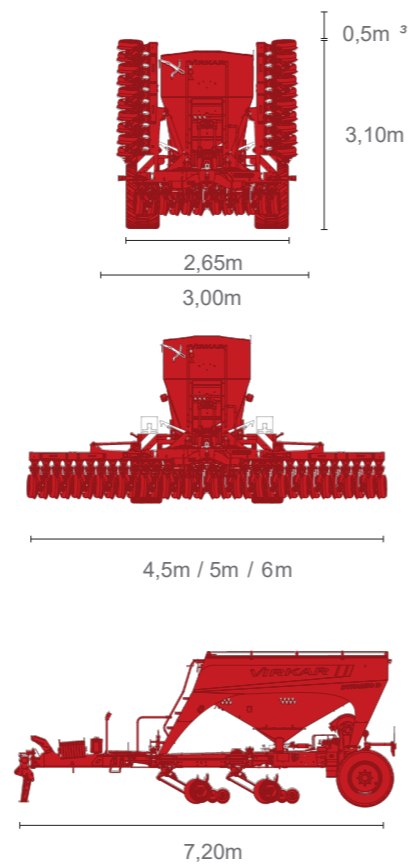

¹ Variable depending on the configuration kits
² Variable depending on the seeds
³ Available only with 25 cm spacing



DYNAMIC D Series

VIRKAR DYNAMIC DIRECT DRILL SEEDER OFFERS A HIGH PRECISION AND QUALITY SOWING WITH THE MOST ADVANCED NO-TILLAGE SYSTEM IN THE MARKET TO ACHIEVE A GREAT SEED GERMINATION AND BETTER PROFITS.

MODULAR DESIGN

It suits your needs, with the possibility to add a variety of optional kits.

LOW OPERATIVE COSTS

High load capacity, low drag, low consumption hydraulic system and simple low cost maintenance.

HIGH MANOEUBRAVILITY

Due to the directional axis arrangement which allows making turns easy and reaching every corner of the land.



The directional axis provides a new freedom, sowing on a curved path. The system frees up tension in the coulter arms, extending the life of components. It can be locked for road transport.

Control in a simple way with an advanced hydraulic system to lift, lower and adjust an optimum coulter pressure on the seed units from the tractor cab. Independent hydraulic system designed to have a low fuel consumption, allowing pressure to be adjusted on the field.

The most advanced no-tillage system on the market. It can be used to work on different types of soil and in the most difficult conditions involving stones, harvest residue and high moisture. The hydraulic control of the single disc with parallelism system allows sowing throughout the entire depth range with low maintenance costs.

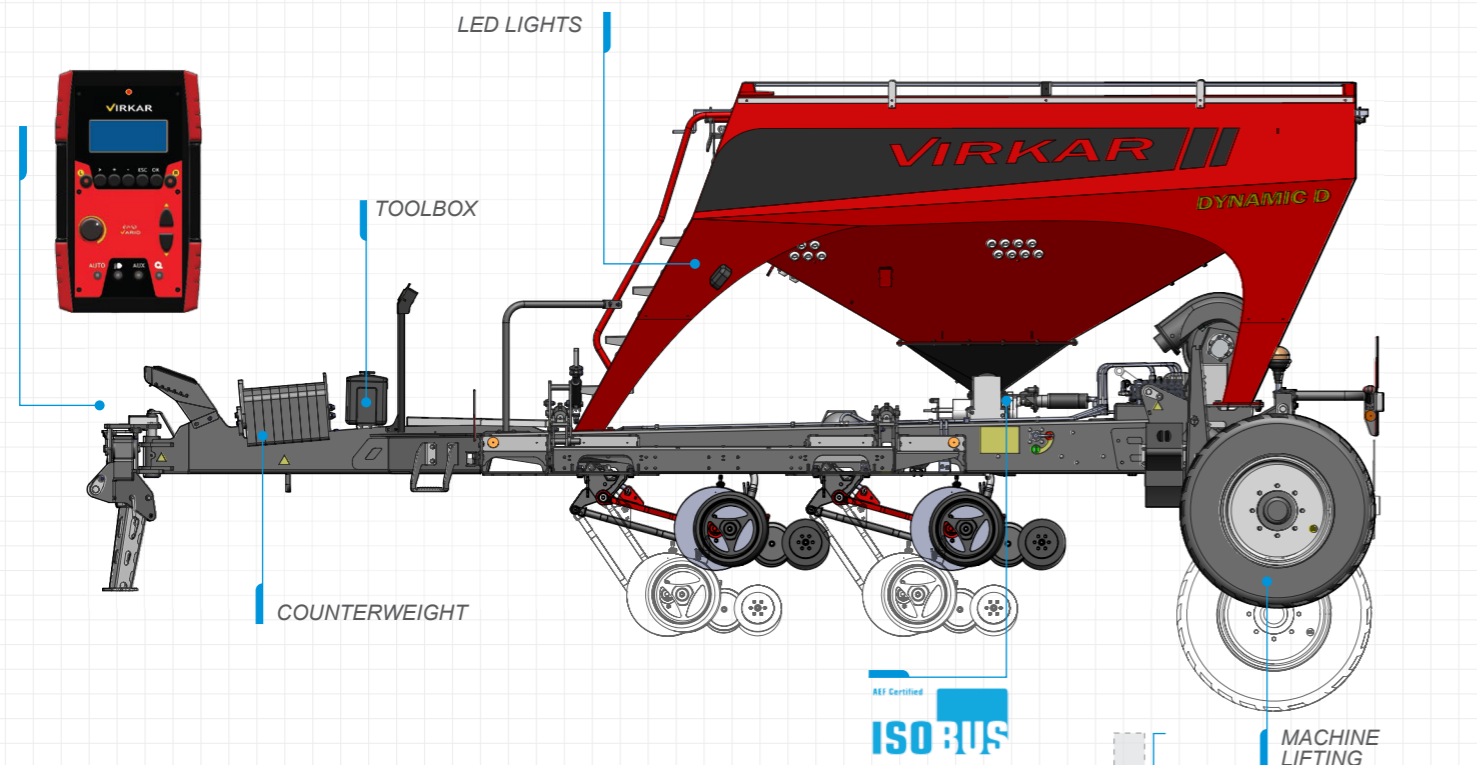

1 PRODUCT: 5.300 L (6.800 L)
 2 PRODUCTS: 1.850 (2.350 L) / 3.440 L (4.440 L)
 3 PRODUCTS: 1.850 / 3.000 / 350 L

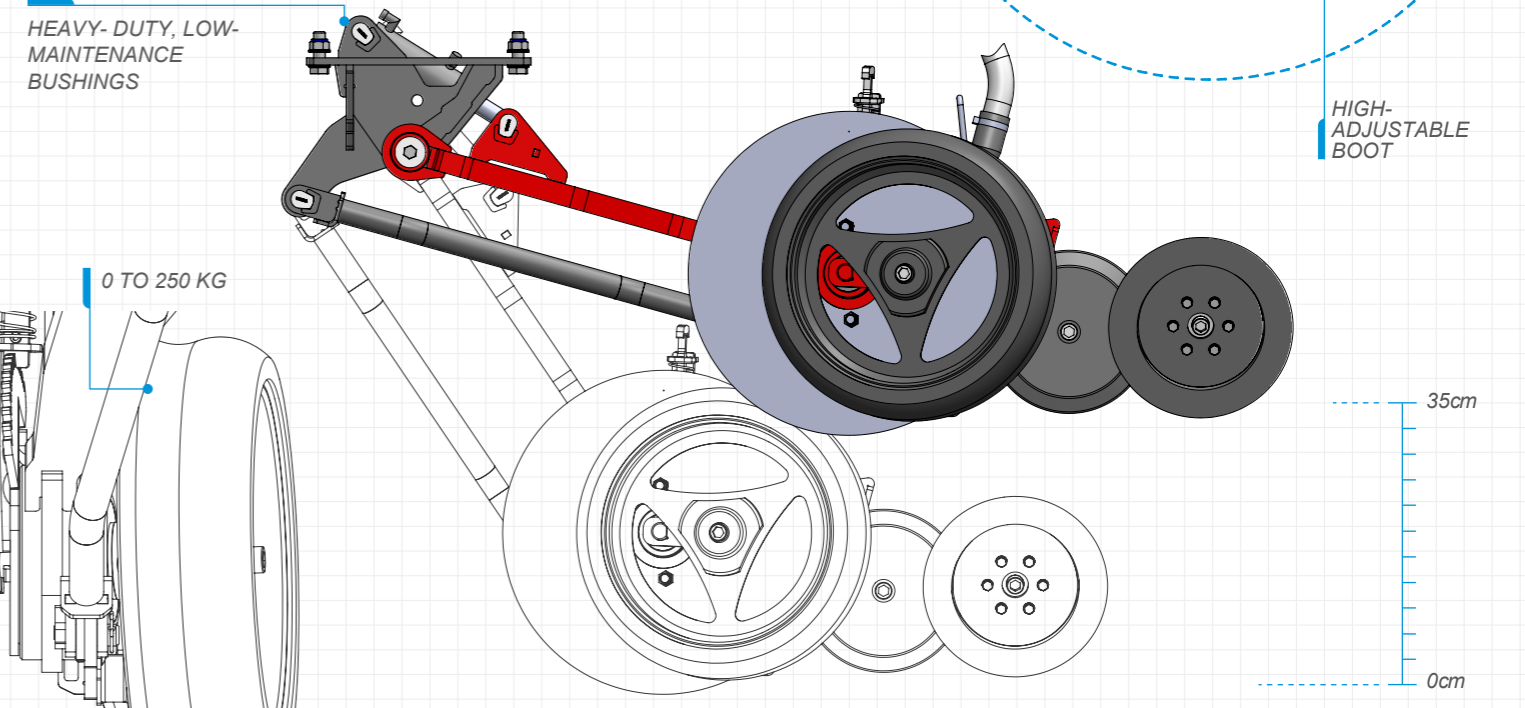
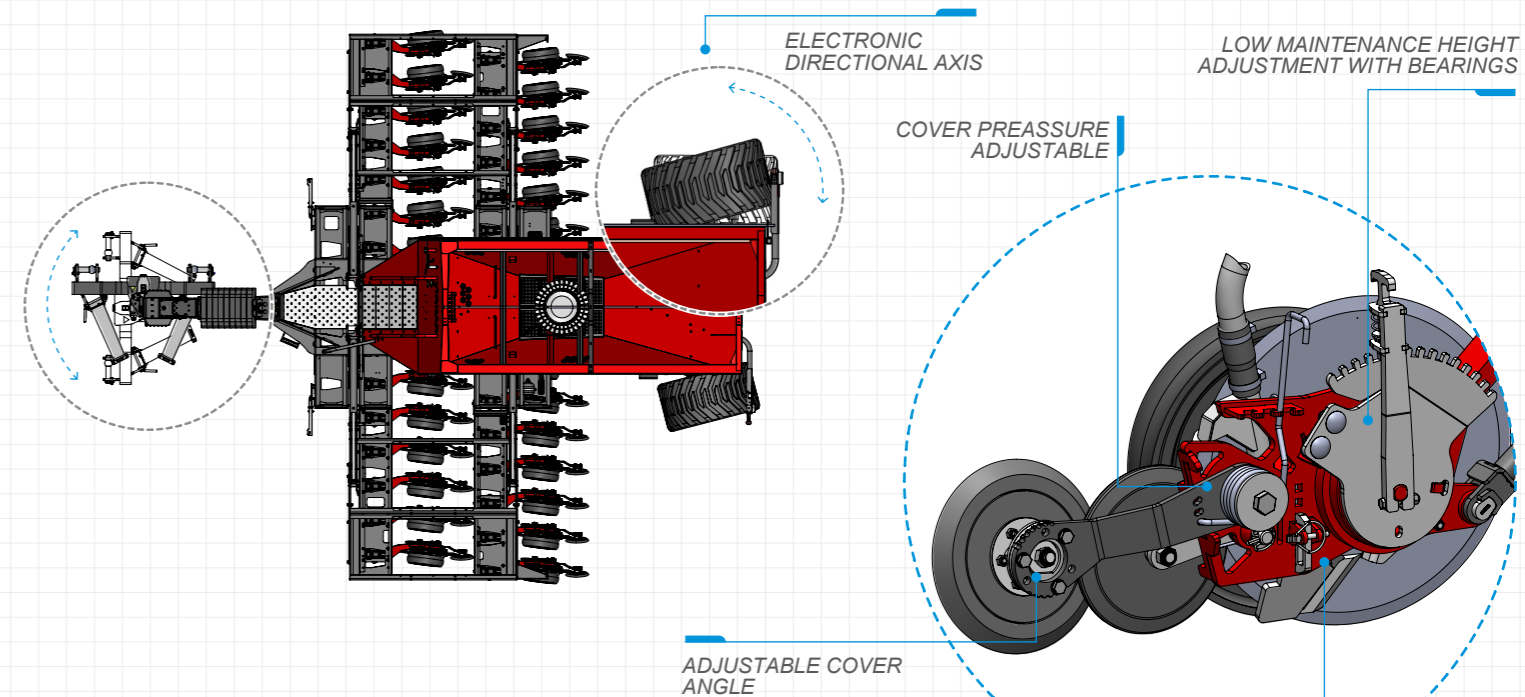
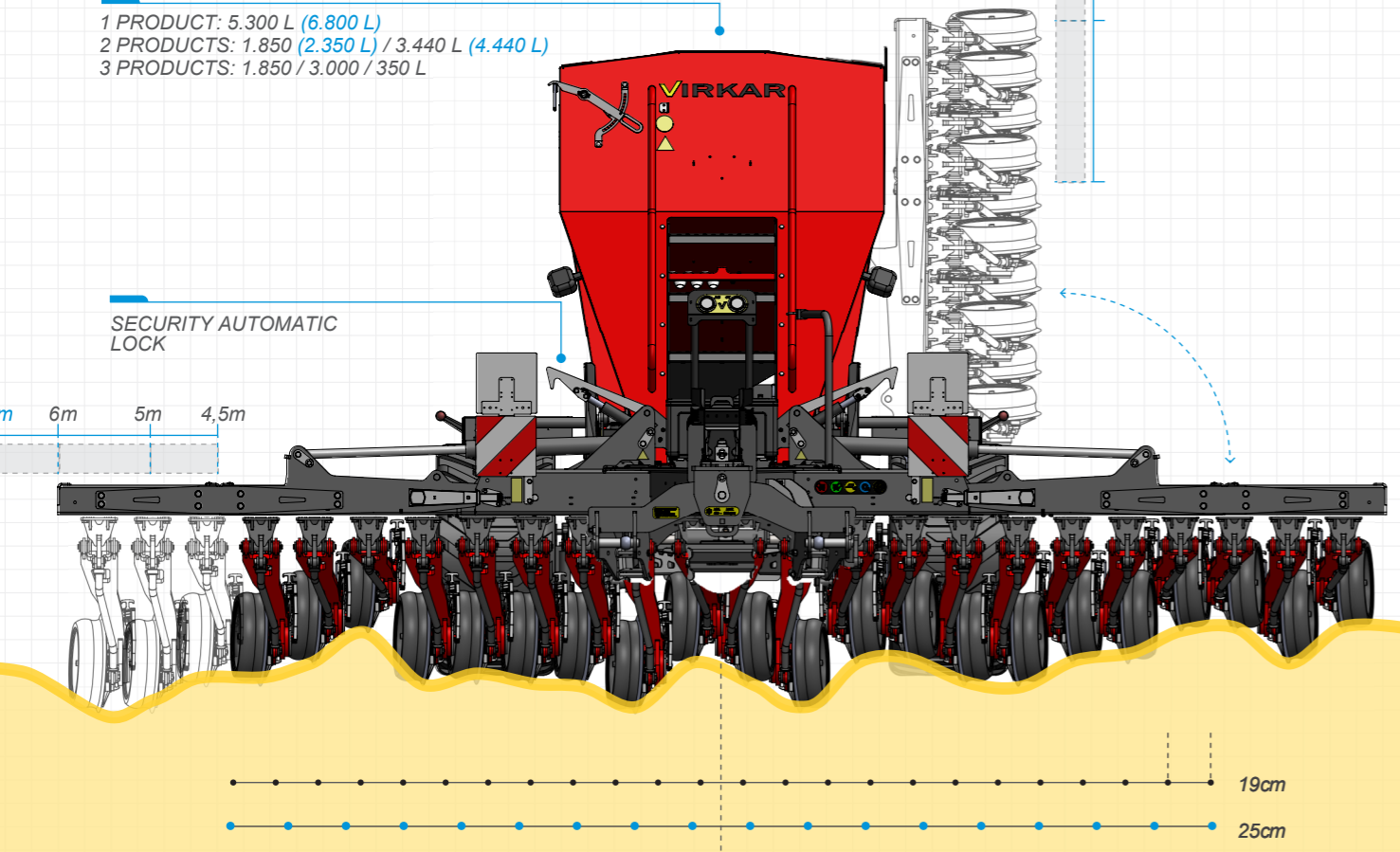

WITHOUT COMPACTION PERFECT GERMINATION PRECISE DEPTH WITH PARALLELISM AND GRAIN TREAD